

## Metallized Polypropylene (PP) - Capacitors for DC-Link Applications. Capacitances from 140 $\mu\text{F}$ to 8250 $\mu\text{F}$ . Rated Voltages from 450 VDC to 1500 VDC.

### Special Features

- Very high volume/capacitance ratio
- Self-healing, internal safety disconnecter
- Safe contact configurations by screwable plates
- Dry construction without electrolyte or oil
- Very low dissipation factor
- Negative capacitance change versus temperature
- Very low dielectric absorption
- According to RoHS 2011/65/EU
- Customer-specific tabs, capacitances or voltages on request
- 105° C version on request

### Typical Applications

As intermediate circuit capacitor e. g. in high power converter technology

### Construction

#### Dielectric:

Polypropylene (PP) film

#### Capacitor electrodes:

Vacuum-deposited

#### Internal construction:

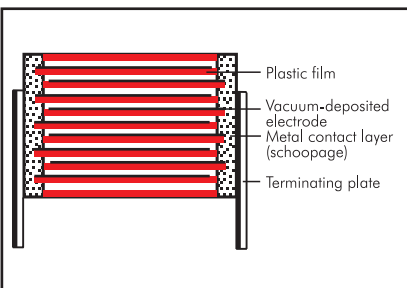

#### Encapsulation:

Solvent resistant, flame-retardant plastic case with PU seal

#### Terminations:

Tinned plates, customized plate configurations are possible.

#### Marking:

Colour: Black. Marking: Gold.

### Electrical Data

**Capacitance range:** 140  $\mu\text{F}$  to 8250  $\mu\text{F}$

#### Rated voltages:

450 VDC, 900 VDC, 1500 VDC

**Capacitance tolerance:**  $\pm 10\%$

#### Operating temperature:

$-55^\circ\text{C}$  to  $+85^\circ\text{C}$  ( $+105^\circ\text{C}$  on request)

#### Insulation resistance at $+20^\circ\text{C}$ :

$\geq 30\,000$  sec ( $\text{M}\Omega \times \mu\text{F}$ )

Measuring voltage: 100 V/1 min.

**Self-inductance:**  $\leq 50$  nH depending on tab configuration

**ESR at  $+20^\circ\text{C}$ :** See General Data.

**Test voltage:**  $1.5 U_r$ , 10 sec

**Dielectric absorption:** 0.05 %

#### Voltage derating:

A derating factor of 1.35% per K must be applied from  $+70^\circ\text{C}$  for AC currents ( $I_{\text{rms}}$ )

#### Reliability:

Operational life  $> 100\,000$  hours at  $70^\circ\text{C}$  hot spot

Failure rate  $< 50$  fit (hot spot  $\leq 70^\circ\text{C}$ )

#### Specific dissipation:

See General Data.

**Standards:** in accordance with IEC 61071

### Mounting Recommendation

Excessive mechanical strain, e.g. pressure or shock onto the capacitor body, is to be avoided during mounting and usage of the capacitors. When fixing the capacitor the screw torque is to be limited to max. 5 Nm.

### Packing

Transportation-safe packing in cardboard boxes.

For further details and graphs please refer to Technical Information.

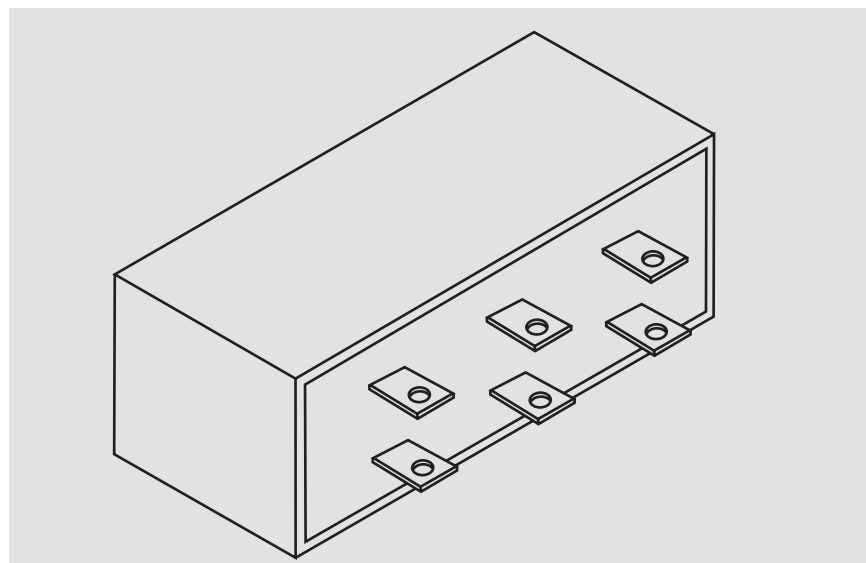

## Continuation

### General Data

$U_R$	$C_N$	$E_N$ $W_S$	Size (mm)			$I_{rms}$ (max.) A	$\hat{I}^*$ kA	$I_S^*$ kA	ESR (1 kHz)* m $\Omega$	$R_{th}^*$ K/W	Approx. weight g	Part number
			W	H	L							
450 VDC	1440 $\mu$ F	146	84	66	179	100	4.6	18.6	0.3	2.8	1220	DCHCH07144JB00KS00
	2400 "	243	84	66	291	170	7.7	30.9	0.2	1.8	1985	DCHCH07240JH00KS00
	3000 "	304	107	91	179	120	6.7	26.7	0.3	2.0	2145	DCHCH07300JC00KS00
	4950 "	501	130	114	179	140	8.7	34.9	0.3	1.5	3265	DCHCH07495JE00KS00
	5000 "	506	107	91	291	190	11.1	44.5	0.2	1.3	3485	DCHCH07500JI00KS00
	8250 "	835	130	114	291	210	14.5	58.1	0.2	1.1	5305	DCHCH07825JJ00KS00
900 VDC	450 $\mu$ F	182	84	66	179	90	2.2	8.8	0.5	2.8	1220	DCHCN06450JB00KS00
	750 "	304	84	66	291	140	3.7	14.6	0.3	1.8	1985	DCHCN06750JH00KS00
	940 "	381	107	91	179	100	2.9	11.6	0.5	2.0	2145	DCHCN06940JC00KS00
	1500 "	608	130	114	179	110	3.5	14.1	0.5	1.5	3265	DCHCN07150JE00KS00
	1560 "	632	107	91	291	160	4.8	19.3	0.3	1.3	3485	DCHCN07156JI00KS00
	2600 "	1053	130	114	291	180	6.1	24.4	0.3	1.1	5305	DCHCN07260JJ00KS00
1500 VDC	140 $\mu$ F	158	84	66	179	60	1.2	4.9	0.9	2.8	1220	DCHCS06140JB00KS00
	230 "	259	84	66	291	100	2.0	8.1	0.6	1.8	1985	DCHCS06230JH00KS00
	280 "	315	107	91	179	80	1.5	6.1	0.8	2.0	2145	DCHCS06280JC00KS00
	460 "	518	130	114	179	90	1.8	7.3	0.8	1.5	3265	DCHCS06460JE00KS00
	470 "	529	107	91	291	130	2.5	10.2	0.5	1.3	3485	DCHCS06470JI00KS00
	790 "	889	130	114	291	150	3.1	12.5	0.4	1.1	5305	DCHCS06790JJ00KS00

\* General guide

Customer-specific tabs, capacitances or voltages on request

External wiring:

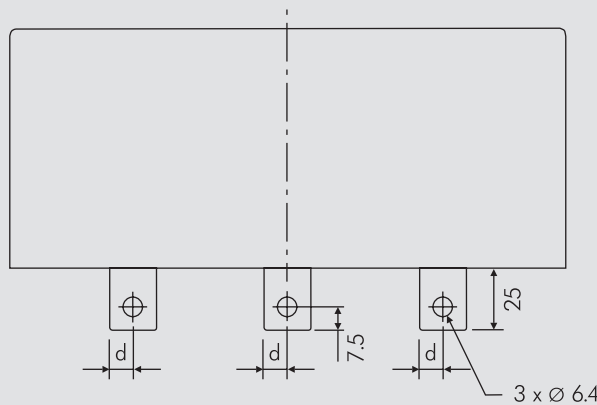
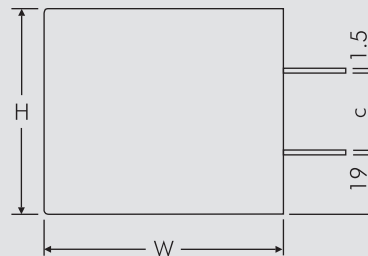
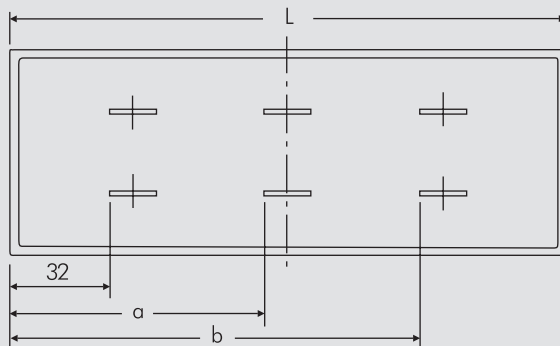
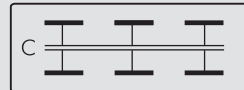

W	H	L	a	b	c	d
84	66	179	82	132	25	7.5
107	91	179	82	132	50	7.5
130	114	179	82	132	73	7.5
84	66	291	135.5	239	25	10
107	91	291	135.5	239	50	10
130	114	291	135.5	239	73	10

Dims. in mm. Case tolerances: general tolerances in accordance with ISO 2768-1 C (approximate)

Rights reserved to amend design data without prior notification.



A WIMA part number consists of 18 digits and is composed as follows:

- Field 1 - 4: Type description
- Field 5 - 6: Rated voltage
- Field 7 - 10: Capacitance
- Field 11 - 12: Size and PCM
- Field 13 - 14: Version code (e.g. Snubber versions)
- Field 15: Capacitance tolerance
- Field 16: Packing
- Field 17 - 18: Pin length (untaped)

1	2	3	4	5	6	7	8	9	10	11	12	13	14	15	16	17	18
<b>M</b>	<b>K</b>	<b>S</b>	<b>2</b>	<b>C</b>	<b>0</b>	<b>2</b>	<b>1</b>	<b>0</b>	<b>0</b>	<b>1</b>	<b>A</b>	<b>0</b>	<b>0</b>	<b>M</b>	<b>S</b>	<b>S</b>	<b>D</b>
MKS 2				63 VDC		0.01 $\mu$ F			2.5x6.5x7.2		-		20%	bulk	6 -2		

<p><b>Type description:</b></p> <p>SMD-PET = SMDT                  SMD-PEN = SMDN                  SMD-PPS = SMDI                  FKP 02 = FKPO                  MKS 02 = MKS0                  FKS 2 = FKS2                  FKP 2 = FKP2                  FKS 3 = FKS3                  FKP 3 = FKP 3                  MKS 2 = MKS2                  MKP 2 = MKP2                  MKS 4 = MKS4                  MKP 4C = MKPC                  MKP 4 = MKP4                  MKP 10 = MKP1                  FKP 1 = FKP1                  MKP-X2 = MKX2                  MKP-X1 R = MKX1                  MKP-Y2 = MKY2                  MP 3-X2 = MPX2                  MP 3-X1 = MPX1                  MP 3-Y2 = MPY2                  MP 3R-Y2 = MPRY                  MKP 4F = MKPF                  Snubber MKP = SNMP                  Snubber FKP = SNFP                  GTO MKP = GTOM                  DC-LINK MKP 3 = DCP3                  DC-LINK MKP 4 = DCP4                  DC-LINK MKP 4S = DCP5                  DC-LINK MKP 5 = DCP5                  DC-LINK MKP 6 = DCP6                  DC-LINK HC = DCHC                  DC-LINK HY = DCHY</p>	<p><b>Rated voltage:</b></p> <p>50 VDC = B0                  63 VDC = C0                  100 VDC = D0                  250 VDC = F0                  400 VDC = G0                  450 VDC = H0                  520 VDC = H2                  600 VDC = I0                  630 VDC = J0                  700 VDC = K0                  800 VDC = L0                  850 VDC = M0                  900 VDC = N0                  1000 VDC = O1                  1100 VDC = P0                  1200 VDC = Q0                  1250 VDC = R0                  1500 VDC = S0                  1600 VDC = T0                  2000 VDC = U0                  2500 VDC = V0                  3000 VDC = W0                  4000 VDC = X0                  6000 VDC = Y0                  250 VAC = 0W                  275 VAC = 1W                  300 VAC = 2W                  305 VAC = AW                  350 VAC = BW                  440 VAC = 4W                  500 VAC = 5W                  ...</p>	<p><b>Capacitance:</b></p> <p>22 pF = 0022                  47 pF = 0047                  100 pF = 0100                  150 pF = 0150                  220 pF = 0220                  330 pF = 0330                  470 pF = 0470                  680 pF = 0680                  1000 pF = 1100                  1500 pF = 1150                  2200 pF = 1220                  3300 pF = 1330                  4700 pF = 1470                  6800 pF = 1680                  0.01 <math>\mu</math>F = 2100                  0.022 <math>\mu</math>F = 2220                  0.047 <math>\mu</math>F = 2470                  0.1 <math>\mu</math>F = 3100                  0.22 <math>\mu</math>F = 3220                  0.47 <math>\mu</math>F = 3470                  1 <math>\mu</math>F = 4100                  2.2 <math>\mu</math>F = 4220                  4.7 <math>\mu</math>F = 4470                  10 <math>\mu</math>F = 5100                  22 <math>\mu</math>F = 5220                  47 <math>\mu</math>F = 5470                  100 <math>\mu</math>F = 6100                  220 <math>\mu</math>F = 6220                  1000 <math>\mu</math>F = 7100                  1500 <math>\mu</math>F = 7150                  ...</p>	<p><b>Size:</b></p> <p>4.8x3.3x3 Size 1812 = KA                  4.8x3.3x4 Size 1812 = KB                  5.7x5.1x3.5 Size 2220 = QA                  5.7x5.1x4.5 Size 2220 = QB                  7.2x6.1x3 Size 2824 = TA                  7.2x6.1x5 Size 2824 = TB                  10.2x7.6x5 Size 4030 = VA                  12.7x10.2x6 Size 5040 = XA                  15.3x13.7x7 Size 6054 = YA                  2.5x7x4.6 PCM 2.5 = 0B                  3x7.5x4.6 PCM 2.5 = 0C                  2.5x6.5x7.2 PCM 5 = 1A                  3x7.5x7.2 PCM 5 = 1B                  2.5x7x10 PCM 7.5 = 2A                  3x8.5x10 PCM 7.5 = 2B                  3x9x13 PCM 10 = 3A                  4x9x13 PCM 10 = 3C                  5x11x18 PCM 15 = 4B                  6x12.5x18 PCM 15 = 4C                  5x14x26.5 PCM 22.5 = 5A                  6x15x26.5 PCM 22.5 = 5B                  9x19x31.5 PCM 27.5 = 6A                  11x21x31.5 PCM 27.5 = 6B                  9x19x41.5 PCM 37.5 = 7A                  11x22x41.5 PCM 37.5 = 7B                  19x31x56 PCM 48.5 = 8D                  25x45x57 PCM 52.5 = 9D                  ...</p> <p><b>Version code:</b></p> <p>Standard = 00                  Version A1 = 1A                  Version A1.1.1 = 1B                  Version A2 = 2A                  ...</p>	<p><b>Tolerance:</b></p> <p><math>\pm</math>20% = M  <math>\pm</math>10% = K  <math>\pm</math>5% = J  <math>\pm</math>2.5% = H  <math>\pm</math>1% = E                  ...</p> <p><b>Packing:</b></p> <p>AMMO H16.5 340x340 = A                  AMMO H16.5 490x370 = B                  AMMO H18.5 340x340 = C                  AMMO H18.5 490x370 = D                  REEL H16.5 360 = F                  REEL H16.5 500 = H                  REEL H18.5 360 = I                  REEL H18.5 500 = J                  ROLL H16.5 = N                  ROLL H18.5 = O                  BLISTER W12 180 = P                  BLISTER W12 330 = Q                  BLISTER W16 330 = R                  BLISTER W24 330 = T                  Bulk/TPS Standard = S                  ...</p> <p><b>Pin length (untaped)</b></p> <p>3.5 <math>\pm</math>0.5 = C9                  6 -2 = SD                  16 <math>\pm</math>1 = P1                  ...</p> <p><b>Pin length (taped)</b></p> <p>none = 00</p>
--	--	---	--	--

The data on this page is not complete and serves only to explain the part number system. Part number information is listed on the pages of the respective WIMA range.